



The foot switch XPEW is a range of foot switches for explosive atmospheres leaving to the operator complete freedom of movement.

They are designed for explosive atmospheres gas/vapours or dust and meet the highest levels of protection.

### TECHNICAL DATA

<b>Material</b>	Zamac, carbon steel
<b>IP rating</b>	IP65 according to EN/IEC 60529
<b>Temperature range</b>	- 20°C ... + 60°C
<b>Certificate</b>	INERIS 04ATEX0042
<b>Marking</b>	II 2 GD Ex db eb IIC T6 Gb or Ex tb IIIC T85°C Db
<b>Features of the contact block</b>	U <sub>max</sub> = 250 V I <sub>max</sub> = 3 A
<b>Cable entry</b>	M20 cable gland
<b>Mechanical endurance</b>	Actuator: 5 million operations - Contact block: 1 million operations

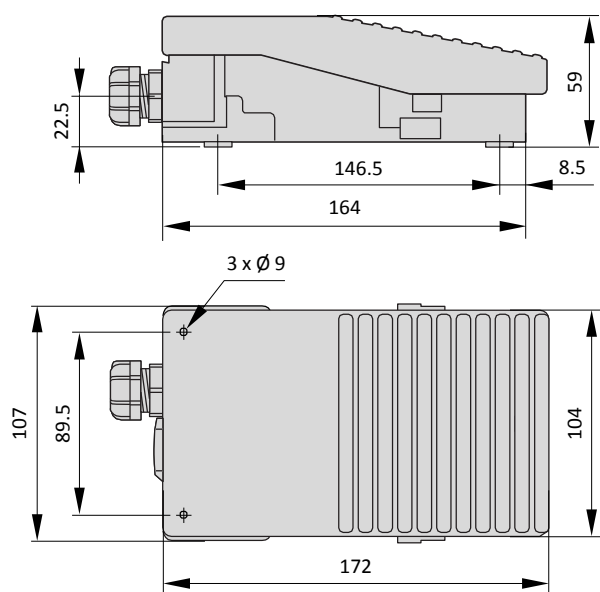

Product code	Control unit type	Colour	Contact
XPEWM110	Contact operation - 1 step	Blue	1 x NC + NO
XPEWM111	Contact operation - 1 step	Blue	2 x NC + NO
XPEWM211	Contact operation - 2 steps	Blue	2 x NC + NO
XPEWR110	Contact operation - 1 step	Orange	1 x NC + NO
XPEWR111	Contact operation - 1 step	Orange	2 x NC + NO
XPEWR211	Contact operation - 2 steps	Orange	2 x NC + NO